

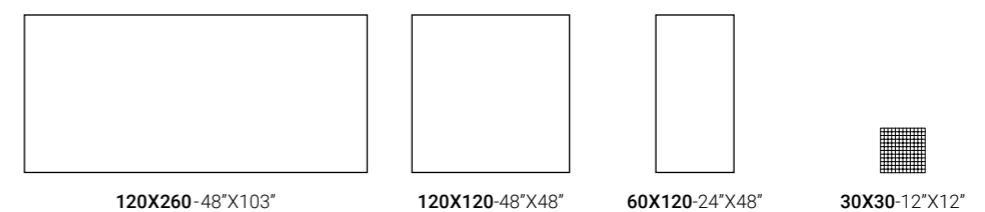





ABS WH



		ABS WH6 120 RM	ABS WH6 12 RM	MK.ABS WH6 30 (T144)
		ABS WH6 260 LP	ABS WH6 120 LP	ABS WH6 12 LP





STA VP

120X260-48"X103"	120X120-48"X48"	60X120-24"X48"	60X60-24"X24"	30X30-12"X12"
STA VP6 260 RM	STA VP6 120 RM	STA VP6 12 RM	STA VP6 60 RM	MK.STA VP6 30
STA VP6 260 LP	STA VP6 120 LP	STA VP6 12 LP	STA VP6 60 LP	













INV WHITE

THE ROOM

GRES PORCELLANATO COLORATO IN MASSA
COLOR BODY PORCELAIN TILE



INV WH

			
120X260-48"X103"	120X120-48"X48"	60X120-24"X48"	30X30-12"X12"
 	INV WH6 120 RM INV WH6 120 LP	INV WH6 12 RM INV WH6 12 LP	MK.INV WH6 30 (T 144)







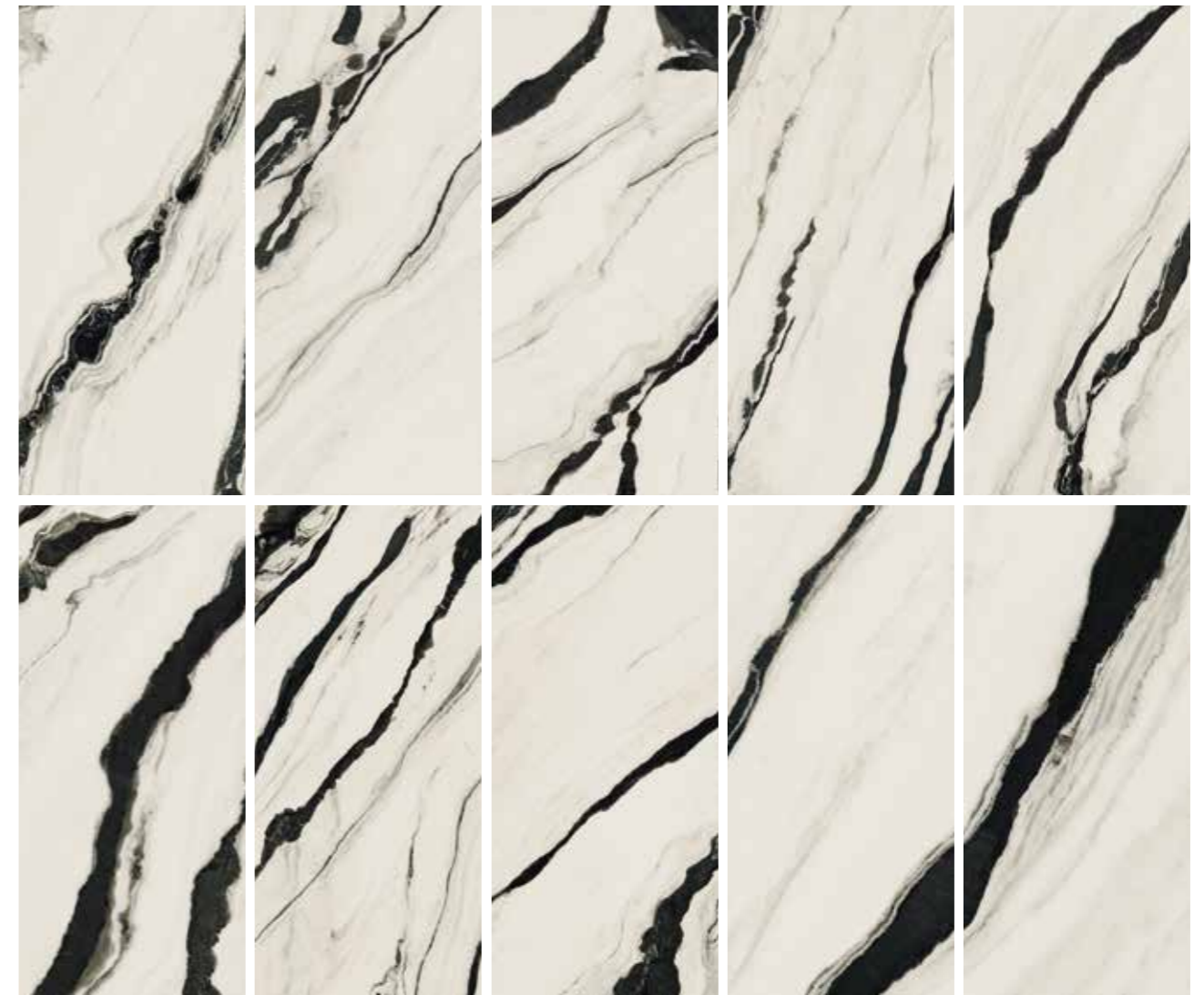

PANDA WHITE

THE ROOM

GRES PORCELLANATO COLORATO IN MASSA
COLOR BODY PORCELAIN TILE



PAN WH

			
120X260-48"X103"	120X120-48"X48"	60X120-24"X48"	30X30-12"X12"
 			
PAN WH6 260 LP	PAN WH6 120 RM PAN WH6 120 LP	PAN WH6 12 RM PAN WH6 12 LP	MK.PAN WH6 30 (T 144)







PAT WH

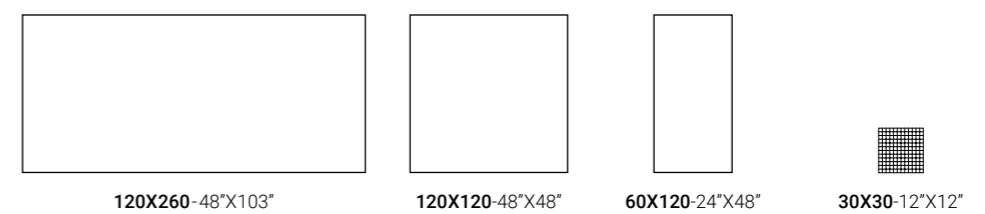

	PAT WH6 120 RM	PAT WH6 12 RM	MK.PAT WH6 30 (T144)
PAT WH6 260 LP	PAT WH6 120 LP	PAT WH6 12 LP	

THE ROOM



CREMO DELICATO

THE ROOM

GRES PORCELLANATO COLORATO IN MASSA
 COLOR BODY PORCELAIN TILE



CRE DL

120X260-48"X103"	120X120-48"X48"	60X120-24"X48"	60X60-24"X24"	30X30-12"X12"
CRE DL6 260 RM	CRE DL6 120 RM	CRE DL6 12 RM	CRE DL6 60 RM	MK.CRE DL6 30
CRE DL6 260 LP	CRE DL6 120 LP	CRE DL6 12 LP	CRE DL6 60 LP	





THE ROOM



SAN PE

120X260-48"X103"	120X120-48"X48"	60X120-24"X48"	60X60-24"X24"	30X30-12"X12"
SAN PE6 260 RM	SAN PE6 120 RM	SAN PE6 12 RM	SAN PE6 60 RM	MK.SAN PE6 30
SAN PE6 260 LP	SAN PE6 120 LP	SAN PE6 12 LP	SAN PE6 60 LP	





THE ROOM







BLACK DAHLIA

THE ROOM

GRES PORCELLANATO COLORATO IN MASSA
 COLOR BODY PORCELAIN TILE



BLA DA

			
120X260-48"X103"	120X120-48"X48"	60X120-24"X48"	30X30-12"X12"
 	BLA DA6 120 RM	BLA DA6 12 RM	MK.BLA DA6 30 (T144)
BLA DA6 260 LP	BLA DA6 120 LP	BLA DA6 12 LP	



GREY ROOTS

EDITION 2021
THE ROOM

GRES PORCELLANATO COLORATO IN MASSA
COLOR BODY PORCELAIN TILE



GRE RO

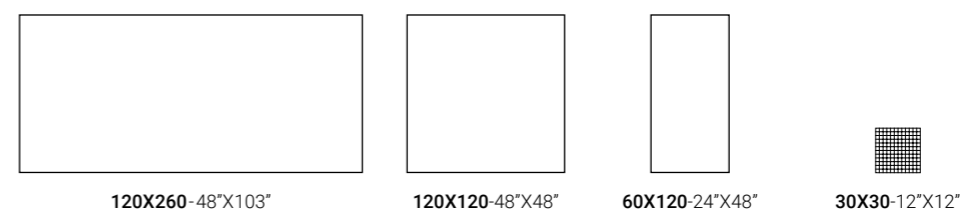

	GRE RO6 120 RM	GRE RO6 12 RM	MK.GRE RO6 30 (T144)
GRE RO6 260 LP	GRE RO6 120 LP	GRE RO6 12 LP	

THE ROOM





BRE DU

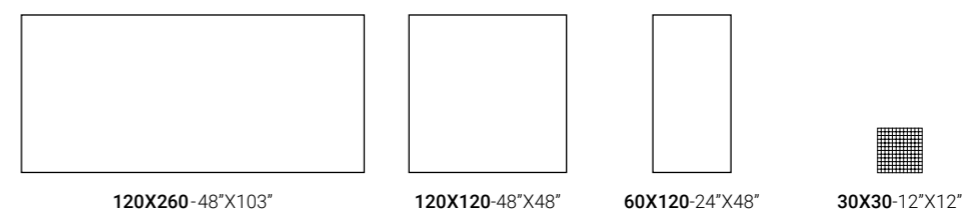

	BRE DU6 120 RM	BRE DU6 12 RM	MK.BRE DU6 30 (T144)
BRE DU6 260 LP	BRE DU6 120 LP	BRE DU6 12 LP	

THE ROOM

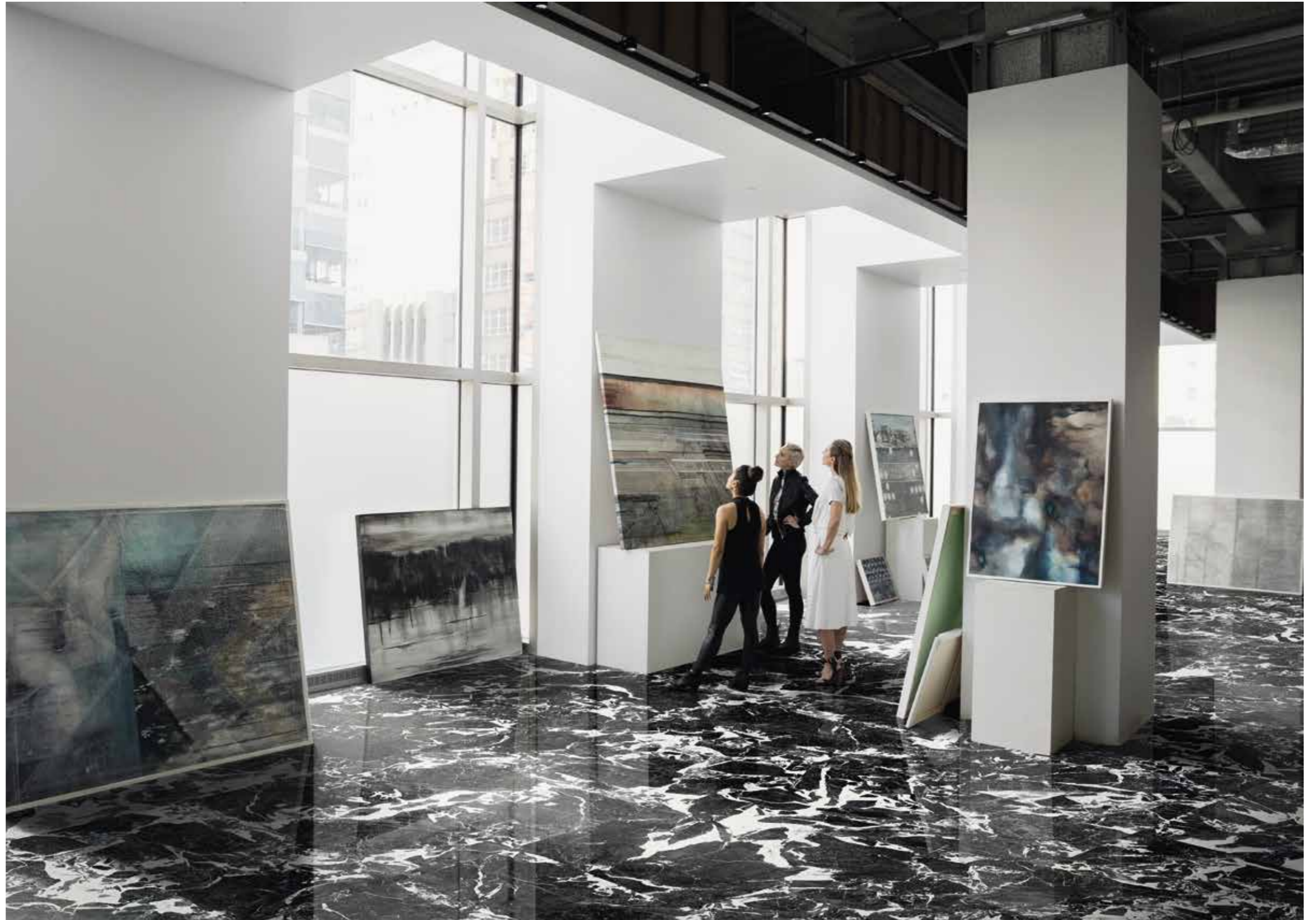



THE ROOM

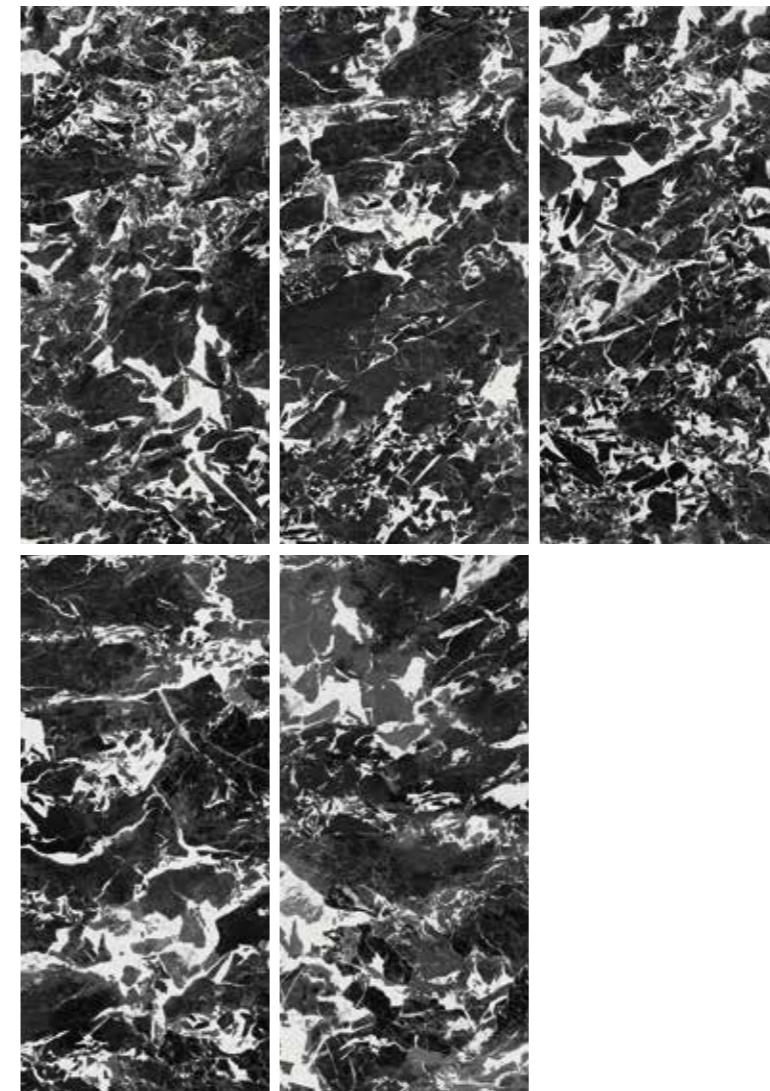

GRA AN

120X260-48"X103"	120X120-48"X48"	60X120-24"X48"	30X30-12"X12"
	GRA AN6 120 RM	GRA AN6 12 RM	MK.GRA AN6 30 (T144)
GRA AN6 260 LP	GRA AN6 120 LP	GRA AN6 12 LP	





THE ROOM



GRES PORCELLANATO COLORATO IN MASSA
 COLOR BODY PORCELAIN TILE



INF BR

				
120X260-48"X103"	120X120-48"X48"	60X120-24"X48"	60X60-24"X24"	30X30-12"X12"
INF BR6 260 RM	INF BR6 120 RM	INF BR6 12 RM	INF BR6 60 RM	MK.INF BR6 30
INF BR6 260 LP	INF BR6 120 LP	INF BR6 12 LP	INF BR6 60 LP	





ONYX AQUA BLUE GOLD

EDITION 2021
THE ROOM

GRES PORCELLANATO COLORATO IN MASSA
COLOR BODY PORCELAIN TILE

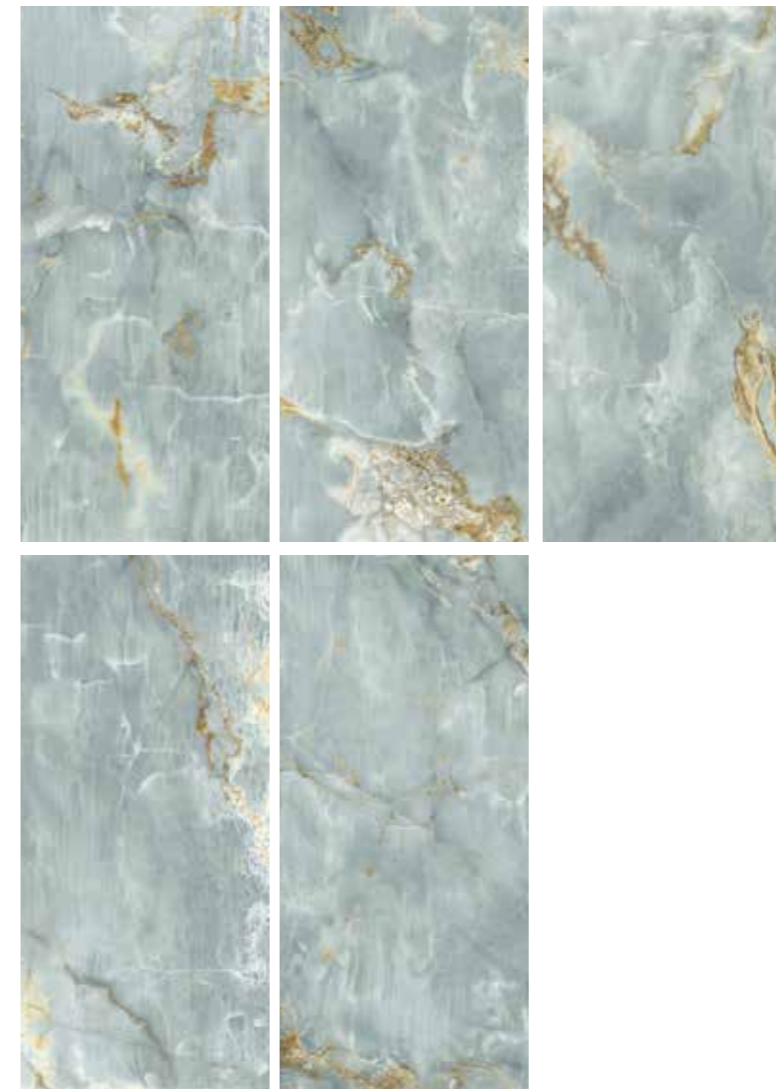

BLU AQ

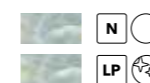
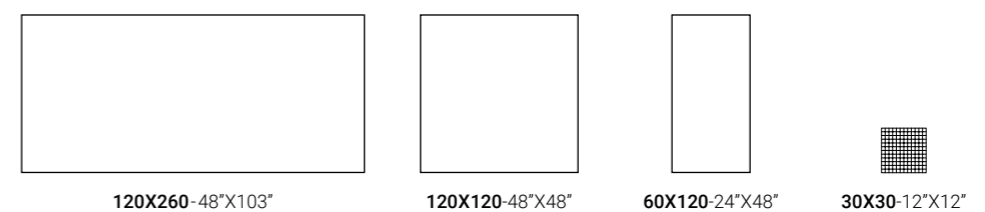

	BLU AQ6 120 RM	BLU AQ6 12 RM	MK.BLU AQ6 30 (T144)
BLU AQ6 260 LP	BLU AQ6 120 LP	BLU AQ6 12 LP	



THE ROOM EDITION 2021

GRES PORCELLANATO COLORATO IN MASSA
COLOR BODY PORCELAIN TILE



ORYX6 260LP
120X260-48"X103"



ORYX6 12LP
60X120-24"X48"





THE ROOM EDITION 2021

GRES PORCELLANATO COLORATO IN MASSA
COLOR BODY PORCELAIN TILE



JAGUAR6 260LP
120X260-48"X103"



JAGUAR6 12LP
60X120-24"X48"



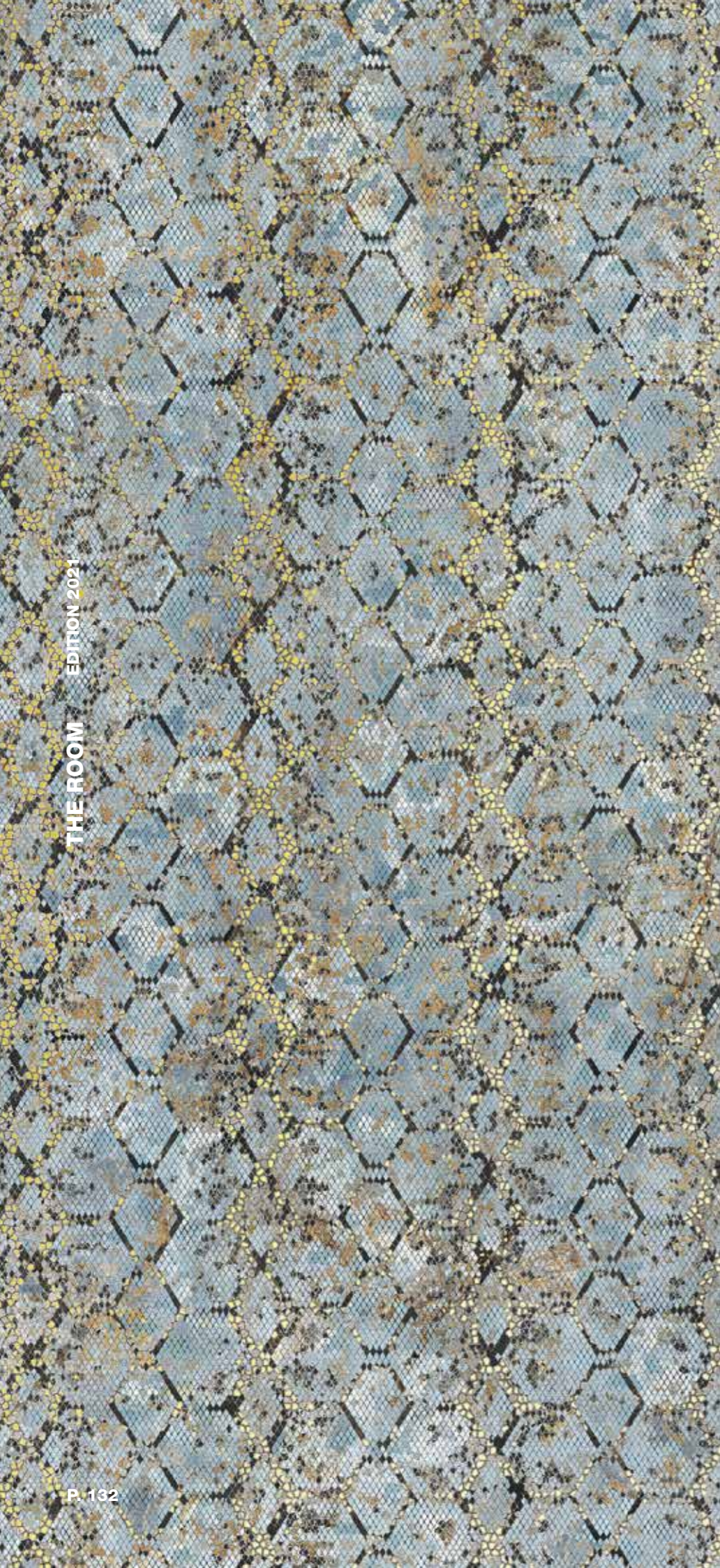

THE ROOM EDITOR 2021

GRES PORCELLANATO COLORATO IN MASSA
COLOR BODY PORCELAIN TILE

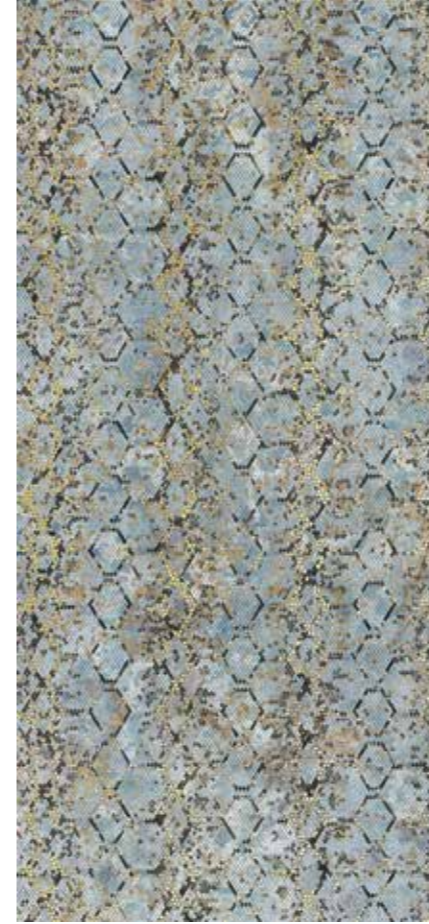

PYTHON6 260LP
120X260-48"X103"



PYTHON6 12LP △ 2



THE ROOM

GRES PORCELLANATO COLORATO IN MASSA
COLOR BODY PORCELAIN TILE



TURTLE6 260LP
120X260-48"X103"

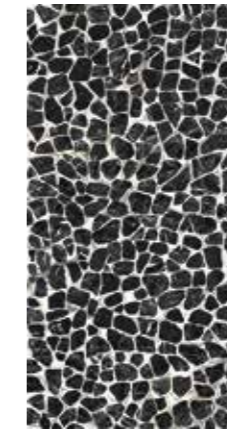

TURTLE6 12LP
60X120-24"X48"





THE ROOM

GRES PORCELLANATO COLORATO IN MASSA
COLOR BODY PORCELAIN TILE



SNAKE6 260LP
120X260-48"X103"



SNAKE6 12LP
60X120-24"X48"





THE ROOM

GRES PORCELLANATO COLORATO IN MASSA
COLOR BODY PORCELAIN TILE



GHEPARD6 260LP
120X260-48"X103"



GHEPARD6 12LP △ 2
60X120-24"X48"



GHEPARD6 120LP
120X120-48"X48"





THE FLOOR

GRES PORCELLANATO COLORATO IN MASSA
COLOR BODY PORCELAIN TILE



ZEBRA6 260LP
120X260-48"X103"



ZEBRA6 12LP
60X120-24"X48"



ZEBRA6 120LP
120X120-48"X48"





the room

GRES PORCELLANATO COLORATO IN MASSA
COLOR BODY PORCELAIN TILE

PEZZI SPECIALI / SPECIAL PIECES

	6X120-2.4"X48" △ 8	6X120-2.4"X48" △ 8
ABS WH	ABS WH6 BT120	ABS WH6 BT120LP
STA VP	STA VP6 BT120	STA VP6 BT120LP
INV WH	INV WH6 BT120	INV WH6 BT120LP
PAN WH	PAN WH6 BT120	PAN WH6 BT120LP
PAT WH	PAT WH6 BT120	PAT WH6 BT120LP
CRE DL	CRE DL6 BT120	CRE DL6 BT120LP
SAN PE	SAN PE6 BT120	SAN PE6 BT120LP
BLA DA	BLA DA6 BT120	BLA DA6 BT120LP
GRE RO	GRE RO6 BT120	GRE RO6 BT120LP
BRE DU	BRE DU6 BT120	BRE DU6 BT120LP
GRA AN	GRA AN6 BT120	GRA AN6 BT120LP
INF BR	INF BR6 BT120	INF BR6 BT120LP
BLU AQ	BLU AQ6 BT120	BLU AQ6 BT120LP

IMBALLI / PACKAGING

FORMATO NOMINALE NOMINAL SIZE	BORDO EDGE	SPESSORE THICKNESS	BOX			PALLET		
			PZ/BOX PCS/BOX	MQ/BOX SM/BOX	KG/BOX KG/BOX	BOX/PALLET BOXES/PALLET	MQ/PALLET SM/PALLET	KG/PALLET KG/PALLET
120X260-48"X103"	RECTIFIED	6,5	1	3,12	49,02	20	62,40	1000,40
120X120-48"X48"	RECTIFIED	6,5	2	2,88	48,45	30	86,40	1473,50
60X120-24"X48"	RECTIFIED	6,5	4	2,88	48,30	16	46,08	792,80
60X60-24"X24"	RECTIFIED	6,5	5	1,80	28,60	32	57,60	935,20
30X30-12"X12" MOSAIC	RECTIFIED	6,5	6	0,54	7,48	72	38,88	558,20









CARATTERISTICHE TECNICHE SPECIFICHE / TECHNICAL FEATURES SPECIFICATIONS

	DIN 51130 (R)	DIN 51097 (A+B+C)	BCR REP. CEC 6/81		DM 14/6/89 N. 236		PENDULUM TEST BS (Inglese)	PENDULUM TEST AS/NZS 4856:2004 (AUSTRALIANO)	PENDULUM TEST UNE ENV 12633:2003 (SPAGNOLO)	BOT 3000 (DCOF)
			G.A.	G.B.	C.A.	G.B.				
THE ROOM	R9	A	>0.4	>0.4	>0.4	>0.4	>25	>25	1	>0,42

Caratteristiche Tecniche Gres Porcellanato

Technical Specifications Porcelain Stoneware

UNI EN 14411 (ISO 13006) - Bla (appendice/appendix G)

CARATTERISTICA Specification	METODO DI PROVA Test methods	REQUISITI PREVISTI DALLA NORMA Requirements in accordance to the standards	VALORE MEDIO IMOLA IMOLA average value
 DIMENSIONI E ASPETTO DIMENSIONS AND APPEARANCE	ISO 10545-2	PROSPETTO G.1 PROSPECT G.1	CONFORME COMPLIANT
 ASSORBIMENTO D'ACQUA WATER ABSORPTION	ISO 10545-3	≤ 0,5%	< 0,1%
 RESISTENZA A FLESSIONE FLEXURAL RESISTANCE		min. / МИН 35 N/mm ²	> 45 N/mm ²
SFORZO DI ROTTURA MODULUS OF RUPTURE	ISO 10545-4	SPESORE / THICKNESS ≥ 7,5 mm: min. 700 N	6,5 mm 1800 N*
		SPESORE* / THICKNESS* < 7,5 mm: min. 1300 N	10 mm* 3000 N*
			20 mm* 13000 N*
 RESISTENZA ALL'ABRAZIONE PROFONDA DEEP ABRASION RESISTANCE	ISO 10545-6	≤ 175 mm ³	< 140 mm ³
 COEFFICIENTE DILATAZIONE TERMICA LINEARE (α) LINEAR EXPANSION THERMIC COEFFICIENT	ISO 10545-8	METODO DISPONIBILE AVAILABLE ON REQUEST	≤ 7x10 ⁻⁶ °C ⁻¹
 RESISTENZA AGLI SBALZI TERMICI RESISTANCE TO SUDDEN TEMPERATURE CHANGES	ISO 10545-9	METODO DISPONIBILE AVAILABLE ON REQUEST	RESISTE RESISTANT
 RESISTENZA AL GELO FROST RESISTANCE	ISO 10545-12	RICHIESTA ALWAYS TESTED	RESISTE RESISTANT
 PRODOTTI CHIMICI AD USO DOMESTICO ED ADDITIVI PER PISCINA HOUSEHOLD CHEMICALS AND SWIMMING POOL WATER CLEANSERS		min. B МИН. В	min. B МИН. В
ACIDI ED ALCALI A BASSA CONCENTRAZIONE ACIDS AND LOW CONCENTRATION ALKALIS	ISO 10545-13	DA LA, LB A LC FROM LA, LB TO LC / DE LA, LB A LC	DA LA, LB A LC FROM LA, LB TO LC / DE LA, LB A LC
ACIDI ED ALCALI AD ALTA CONCENTRAZIONE ACIDS AND HIGH CONCENTRATION ALKALIS		METODO DISPONIBILE AVAILABLE ON REQUEST	METODO DISPONIBILE AVAILABLE ON REQUEST
 RESISTENZA ALLE MACCHIE UGL STAIN RESISTANCE UGL		METODO DISPONIBILE AVAILABLE ON REQUEST	METODO DISPONIBILE AVAILABLE ON REQUEST
	ISO 10545-14		
RESISTENZA ALLE MACCHIE GL STAIN RESISTANCE GL		min. 3 МИН. 3	min. 3 МИН. 3

*VALORI RIFERITI AL FORMATO 60X60 / VALUES REFERRED TO 60X60 SIZE

Symbologia Symbols



imolaceramica.com

Marketing CC Imola

INDICAZIONI D'USO INDICATIONS FOR USE

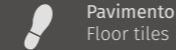

Pavimento
Floor tiles



Rivestimento
Wall tiles

DESTINAZIONI D'USO SUGGESTED APPLICATIONS



Abitazioni
Domestic purpose



Commerciale leggero
Light traffic area



Commerciale
Retail

SUPERFICI SURFACES

Struttura
Structure

Finitura
Finish



Naturale
Natural



* Lappato
Honed

Aspetto superficiale
Surface look



Opaco
Matt



* Lucido
Glossy

Bordo
Edge



RM Rettificato monocalibro
Monocaliber, rectified

STONALIZZAZIONE SHADE VARIATION

V2



SPESORE THICKNESS



6,5

IMBALLO PACKING



CARATTERISTICHE DI VENDITA SALES CHARACTERISTICS



Prodotto venduto al pezzo.
Product sold per item.

Tutti i nostri prodotti, sia al mq che al pezzo, sono venduti unicamente a scatola completa.
All our products are sold only in complete boxes, whether the unit of measure is per item or per square metre.



A brand of
Cooperativa Ceramica d'Imola S.c.

Via V. Veneto, 13
40026 Imola (BO) Italia
Tel. +39 0542 601601
Fax +39 0542 31749

* Le superfici con finitura lappata lucida e levigata sono consigliate per qualsiasi tipo di rivestimento e per pavimenti residenziali o per superfici calpestabili che non hanno un diretto collegamento con l'esterno o che hanno accessi protetti da appositi stuoi. Come è noto tutte le superfici lucide subiscono con l'uso un naturale processo di opacizzazione.
Nel caso dei materiali in gres porcellanato di Imola questo processo è più lento rispetto a qualsiasi altro materiale naturale lavorato a lucido come marmo, pietra, granito. / Surfaces with a honed and polished gloss finish are recommended for any kind of wall tile, residential floor or floors that are not directly connected with the outdoors or whose entrances are protected by mats. As is well known, all gloss surfaces naturally lose their shine over time. With Imola porcelain stoneware this process is slower than other honed natural materials like marble, granite or stone.